

# MINIJET

## 280

LENGTH O.A.	2.79m (±1%)
BEAM O.A.	1.54m (±1.5%)
DRAFT (LOAD DEPENDANT)	0.24m / 0.35m
ENGINE	Rotax ACE 60 ECT
POWER	60hp ≅ 44.13kW
DRY WEIGHT	210kg
SEATING CAPACITY	3 + 1 child
FUEL	PETROL
FUEL CAPACITY	28L
MAX. SPEED	40mph ≅ 64kph
No. TUBE COMPARTMENTS	4
CE DESIGN CATEGORY	C

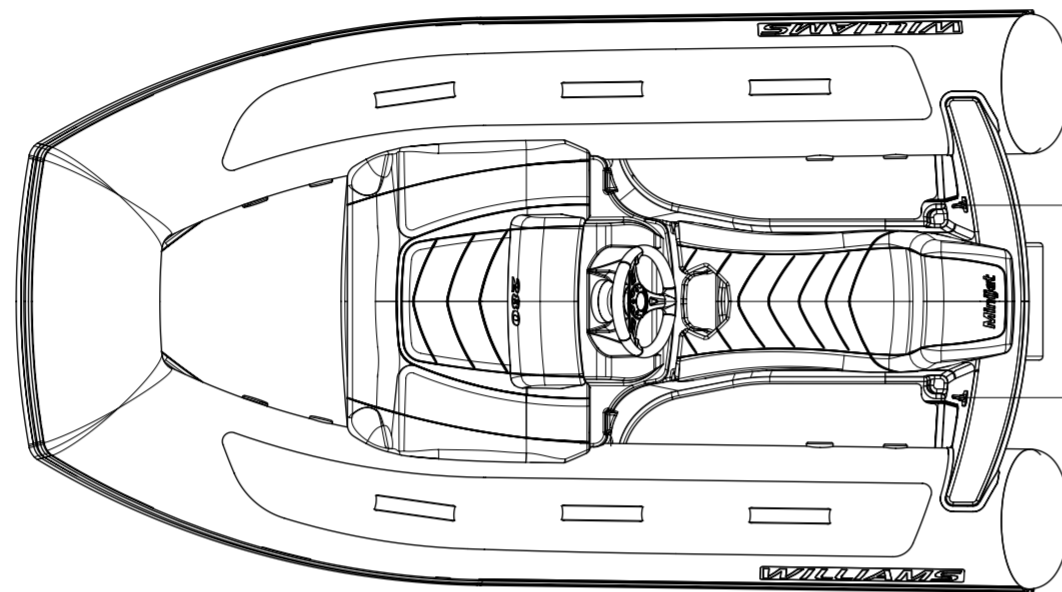

0.5 CTRS  
AFT LIFT POINTS

### NOTES:

1. LENGTH / BEAM TOLERANCE DUE TO VARIATION IN TUBE PRESSURE.
2. AVERAGE DRY WEIGHT STATED;  
ACTUAL WEIGHT DEPENDENT ON OPTIONS FITTED.
3. LOW PROFILE SPEC:
  - REMOVE STEERING WHEEL (QUICK RELEASE TYPE REQUIRED\*)
  - DEFLATE TUBES.
4. CHOCK PROFILE'S DRAWING: RD927  
CHOCKS\* PART NUMBER: 99-0926

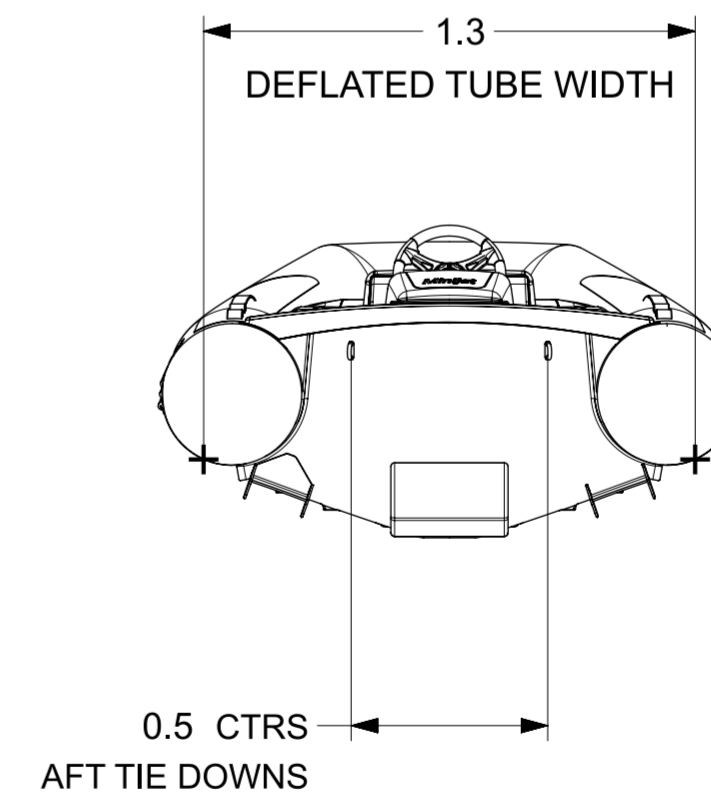
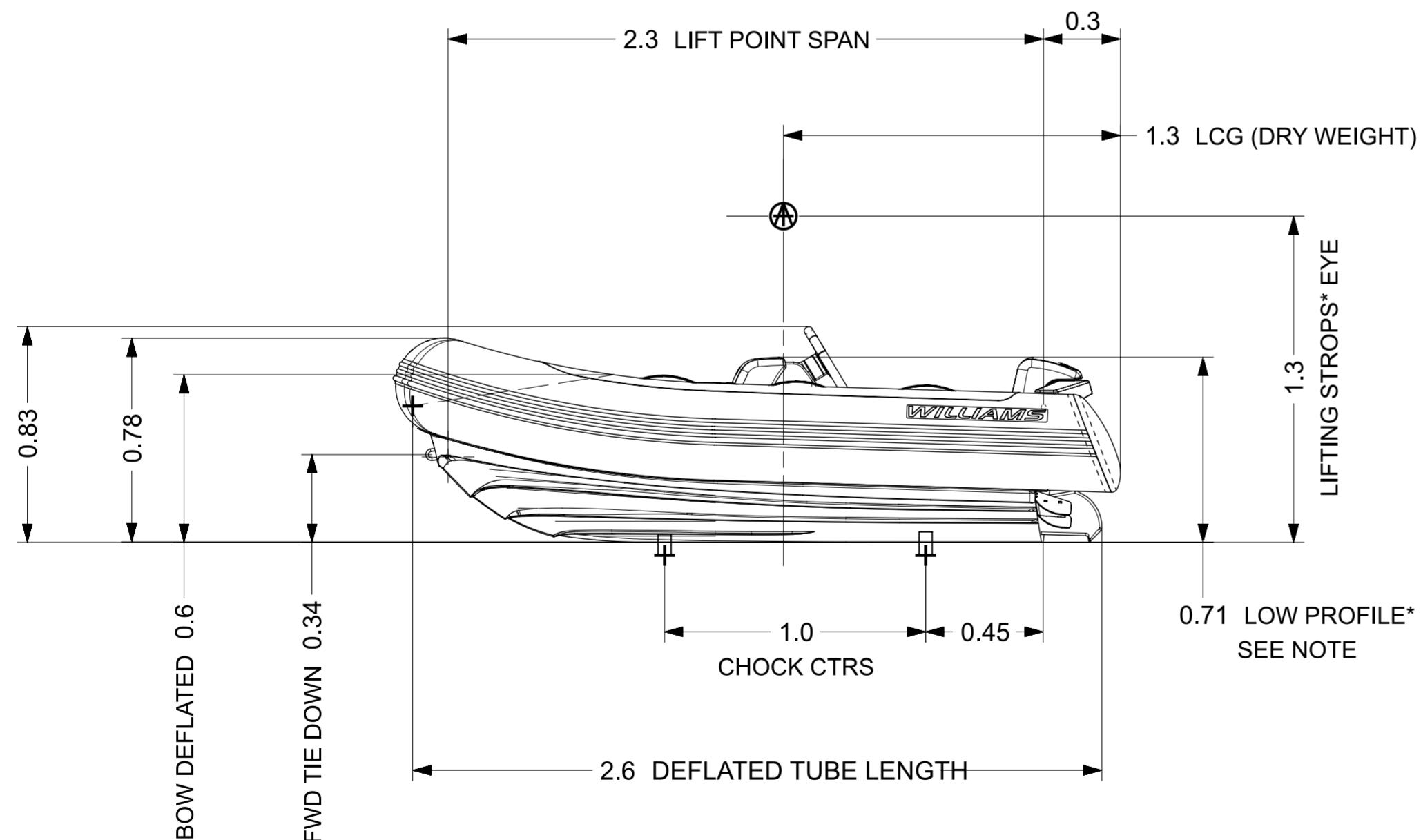

\*OPTIONAL ACCESSORY

REV.	DATE	DETAILS	WE	DBS
1	11/08/2021	PRODUCTION RELEASE	WE	DBS

GENERAL TOL.	0 ±0.50
	0.0 ±0.25
	0.00 ±0.10
	0 ±0.30

NAME	DATE
DRAWN WE	11/08/2021
APPVD DBS	11/08/2021
PROJECT:	-
INSPECTION LEVEL:	-
MATERIAL & FINISH	-
GENERAL SURFACE FINISH	Ra 1.6UM
DIMENSIONS IN MM UNLESS STATED	
DO NOT SCALE DRAWING	

<b>WILLIAMS</b>	
<b>MINIJET 280 (2022MY)</b>	
PART NO.	WPT-000280MJ-2022MY-DATASHEET -dwg.1
SCALE	1:20
SHEET	1 OF 1

NOT FOR PUBLICATION - THIS DRAWING IS THE PROPERTY OF WILLIAMS JET TENDERS LTD. AND IS ISSUED ON CONDITION THAT IT IS NOT COPIED, RE-PRINTED OR DISCLOSED EITHER WHOLLY OR IN PART TO ANY THIRD PARTY NOT AUTHORISED TO RECEIVE IT

REMOVE ALL BURRS & BREAK SHARP EDGES